KIT PART NUMBER 6730035
INSTRUCTIONS FOR INSTALLING BREWER MOUNTING PLATE

CHECK THE PARTS RECEIVED IN THE KIT WITH THE PARTS LIST IN THESE INSTRUCTIONS. IF ANY PARTS ARE MISSING, CONTACT THE NATIONAL VENDORS PARTS DEPARTMENT IMMEDIATELY.

Read these instructions carefully before installing the kit.
Keep these instructions for part numbers and for future reference.

THIS KIT CONTAINS THE FOLLOWING :

PART NUMBER	DESCRIPTION	QUANTITY
6730037	TEMPLATE-PUMP MOUNTING	1
1451097	SCREW-#8-32X.31 HEX HD.TF-BLK.	2
6730041	INSTRUCTIONS-PUMP MOUNTING	1
6734121	BRACKET-MOUNTING-PUMP	1

1. Turn machine power off.
2. Remove cup station from machine, set aside.
3. Remove grounds bucket and waste pail, set aside.
4. Disconnect hose and remove brewer from brewer drive mounting panel by pushing release latch under the brewer and set aside.
5. Remove filter paper cover, paper and filter paper assembly from machine (Note: there will be a harness running to the switch) and set aside.
6. Remove bracket-mount-pump from machine. Disconnect the harness and tubing.
7. Remove pump and motor assembly from bracket-mount-pump.
8. Cutout template part #6730037 as indicated on the engineering drawing.
9. Align the template's center hole with the existing hole on the brewer drive mounting panel (.141 Dia.) and large cutout on the brewer drive mounting panel.
(See figure 13)
10. Drill two .141 diameter holes as shown on template.
11. Install pump and motor assembly on the brewer mounting plate using existing screw that was removed and the two other screws part# 1451097 that are supplied.
(Caution: make sure that all metal shavings are cleaned up.)

12. Install filter paper assembly, filter paper cover, and cup station back in the machine.
13. Restore power back to machine and check brewer assembly for proper operation.

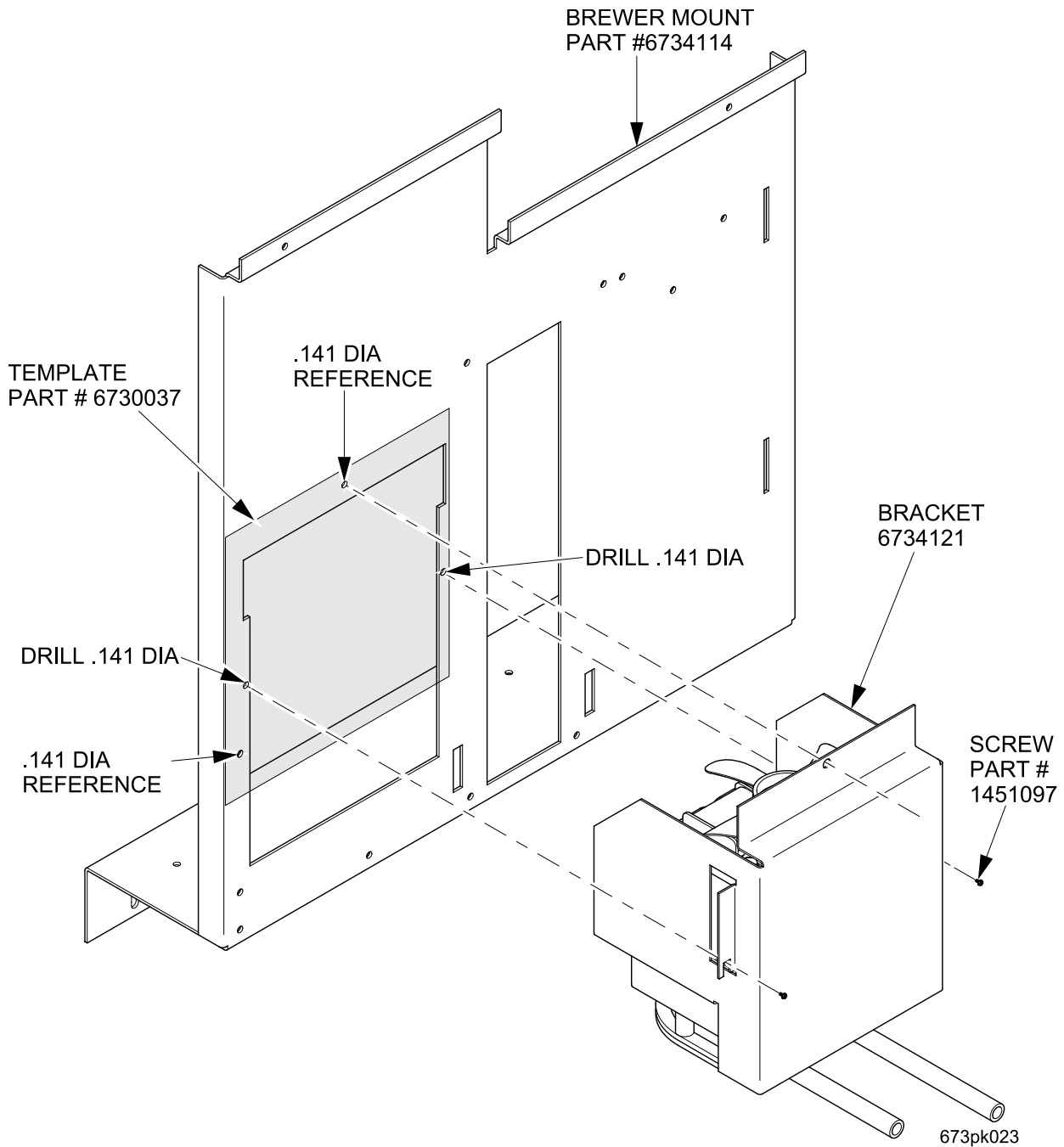

Figure 1